

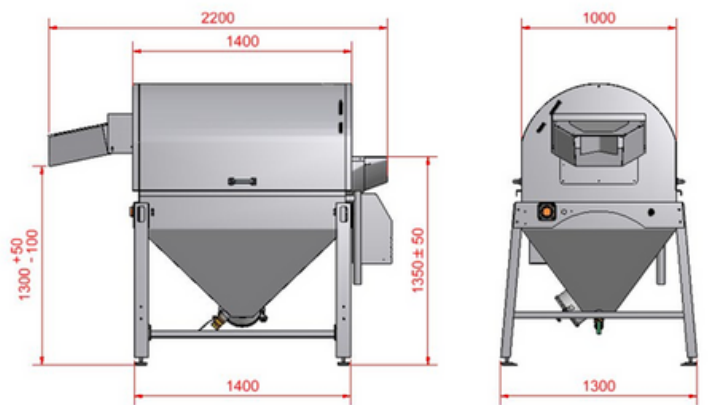

TECHNICAL DATA (003D-164160A)

- Operating voltage: 400 V 3-phase 50 Hz
- If frequency converter: 400 V 1-phase 50Hz
- Connection power: 0.37 kW
- Noise level: <70 dB (average situation)
- Weight: approx. 300 kg
- Product size: maximum dimension 120mm (length, thickness or height must not exceed)
- Capacity: 1000-3000kg / h (depending on the product)



FF WASHING DRUM



The object of the machine is - after the root crops have been peeled and before they are checked and assorted - to rinse the loose peeling ingredients and the enzymes that get released during peeling. The drum may also be used for rinsing sliced products before follow-up processing.

Products can be fed into the machine through the side of the higher porthole while machine is on. Peeled root crops are fed on a steady pace. Processed products come out by the side of the lower bay, after which they are ready for follow-up processing.

The machine does not produce waste. When rinsing/washing fluid expires, dispose it in appropriate manner.

