

TECHNICAL DATA (FF 0037-13090)

- Weight: 250 kg (high model)
- Capacity: high model prox. 800 ltr, low model prox. 250 ltr

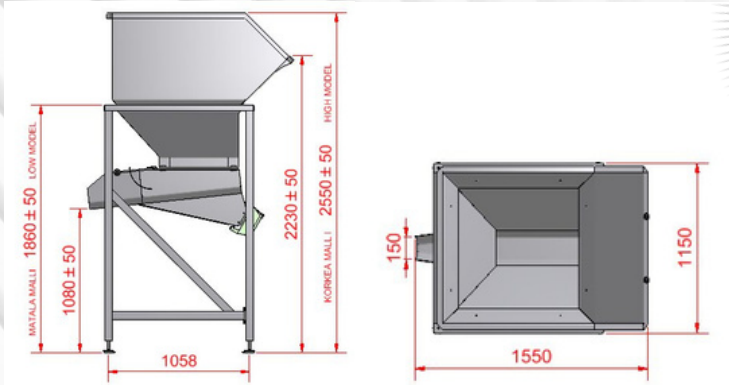

VIBRATORY WEIGHER/FEEDER SILO

Vibratory weigher/feeder silo for drying, interim storage and packaging. The silo has a capacity of 800 liters (or 250 liters). The products are dispensed from the silo into the package with a vibratory conveyor.

The machine has a rack to which a bag can be attached, it is also possible to dispense into a box. The weigher unit measures the weight of the package and stops the conveyor automatically when the desired amount of product has been dispensed.

The frame of the device is made of stainless steel and easy to wash. Variations of this machine are available on request.